

Original
Jokosit[®]
Made in Germany



MADE IN GERMANY

Professionelle Fliesenschneidemaschinen für den perfekten Schnitt
Professional tile cutting machines for the perfect cut

D

Erfinder der Fliesenschneidemaschine

Seit mehr als 70 Jahren ist der Name JOKOSIT untrennbar mit der Erfindung der Fliesenschneidemaschine verbunden. Als A-Lieferant des professionellen Fachhandels sowie des DIY-Werkzeughandels, und dem Qualitätssiegel »Made in Germany« hat sich die Marke Jokosit einen guten Namen gemacht.

2013 wurde JOKOSIT von der Wuppertaler Holtmann GmbH übernommen. Das international agierende Familienunternehmen hat sich auf die Entwicklung, Produktion und den Vertrieb von Fliesenschneidemaschinen, Werkzeugen und Zubehörteilen spezialisiert und nimmt heute im Marktsegment Fliesenverlegung mit eine führende Stellung ein.

JOKOSIT Produkte werden als Premium Markenartikel im Produktportfolio der Holtmann GmbH weiter geführt.



So fing alles an. **How it all began.**

Heutiges **Top-Produkt** aus der Profi-Cut-Serie der Fliesenschneidemaschinen. **A current top product from the Profi-Cut tile cutting machine range.**

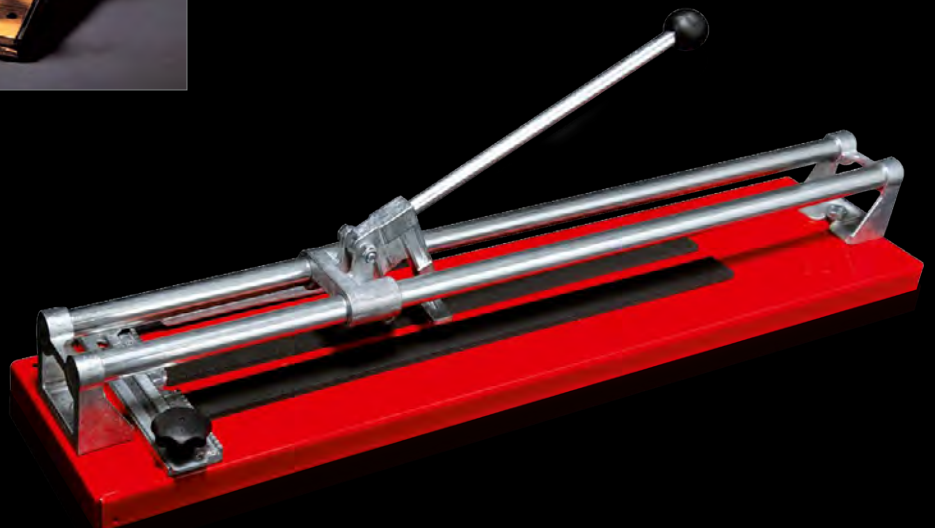

GB

Inventor of the tile cutting machine

The JOKOSIT name has been intrinsically associated with the invention of the tile cutting machine for more than 70 years. A top supplier for professional specialists and the do-it-yourself industry, and a bearer of the "Made in Germany" quality seal, the JOKOSIT brand has made a good name for itself.

In 2013, JOKOSIT was taken over by the Wuppertal-based Holtmann GmbH. The family-owned enterprise, which trades all over the world, specialises in the development, production and sale of tile cutting machines, other tile cutting tools and accessories, and is now one of the leaders in the tiling market segment.

JOKOSIT products have been continued as premium brand items in the Holtmann GmbH product portfolio.

D

Qualität – Made in Germany

JOKOSIT Markenprodukte sind »Made in Germany«. Wir verwenden ausschließlich hochwertige Materialien und legen Wert auf eine sorgfältige Verarbeitung unserer Produkte. Dies ermöglichen wir durch ergonomische Arbeitsplätze, neueste Fertigungstechnologie und ein durchdachtes Qualitätsmanagement. Unsere erfahrenen Mitarbeiter kennen jedes Detail unserer Fliesenschneidemaschinen und entwickeln sie permanent weiter. So sind Sie mit unseren Qualitätsprodukten immer auf dem neuesten Stand der Technik.

_ UNSERE PHILOSOPHIE:

Wir möchten, dass Sie als unser Kunde mit JOKOSIT Produkten besser abschneiden. Daran arbeiten wir Tag für Tag.

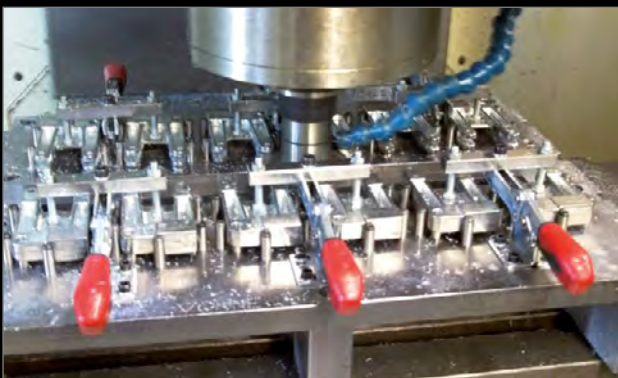
**GB**

Quality – Made in Germany

JOKOSIT products are "Made in Germany". We use only high-quality materials for our products and place a large amount of emphasis on careful craftsmanship, which we achieve through ergonomically designed workstations, state-of-the-art manufacturing technology and well-thought-out quality management. Our experienced employees know our tile cutting machines down to the last detail and are constantly working to develop them further – which is how we ensure that you are always investing in the best equipment available when you invest in our products.

_ OUR PHILOSOPHY:

As our customer, we want you to be able to achieve better results with JOKOSIT products. That is what we're working on every day.



D

Wir agieren international

Langjährige Erfahrung, überzeugendes Fachwissen, hohe Innovationskraft und Leistungsfähigkeit sowie unsere Kundenorientiertheit haben JOKOSIT zu einer der führenden Marken im Bereich Fliesenlegerwerkzeuge gemacht. In vielen Ländern der Welt sind wir mit persönlichen Ansprechpartnern vertreten. Durch die Übernahme der Holtmann GmbH wird das internationale Geschäft zukünftig noch stärker ausgebaut.

GB

We trade all over the world

Many years of experience, excellent technical knowledge, a high capacity for innovation and performance, and our ability to align our products to our customers' needs have made JOKOSIT one of the world's leading manufacturers of tilers' tools. We are represented by personal contacts in many countries around the world, and the takeover by Holtmann GmbH means our international trade will become even stronger in future.

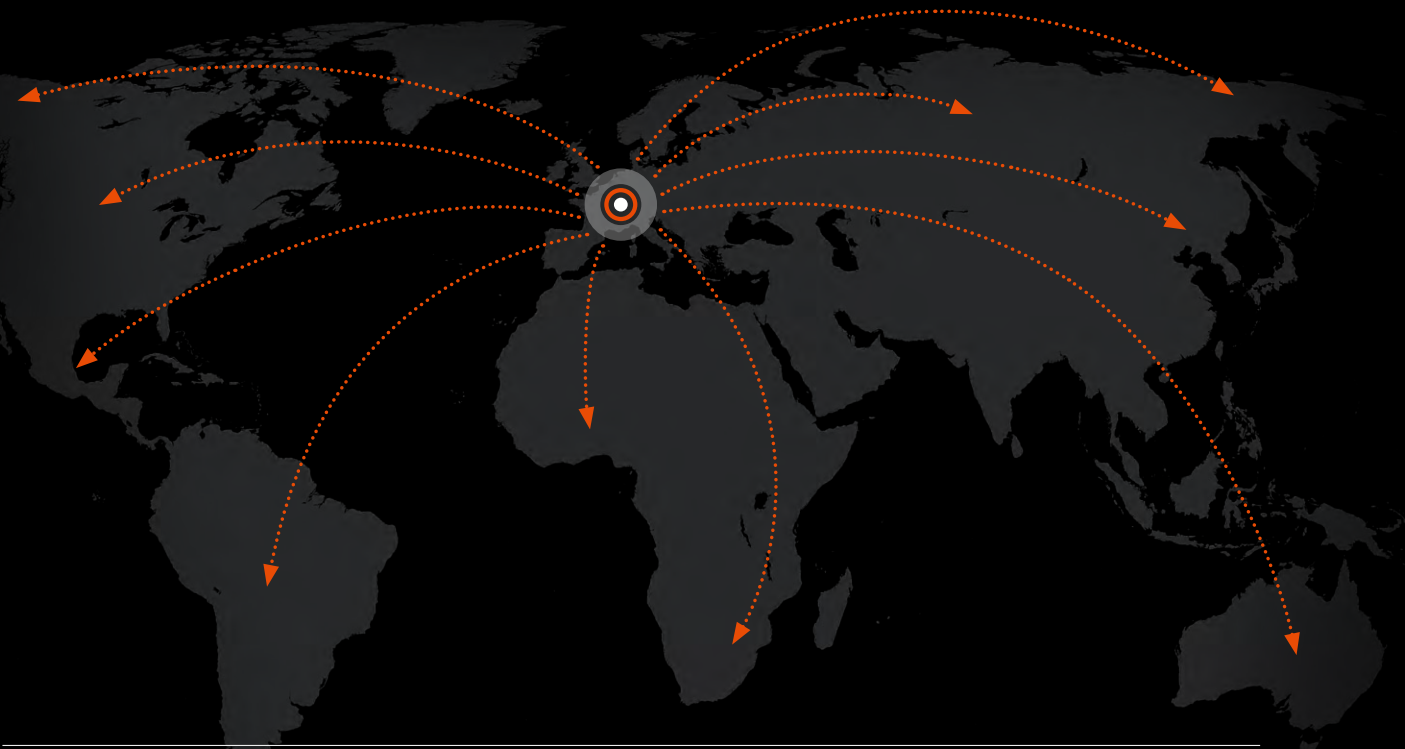

HEUTE UND ZUKÜNFTIG –

INTERNATIONALE GESCHÄFTE DER HOLTSMANN GMBH - DEUTSCHLAND

NOW AND IN THE FUTURE –

INTERNATIONAL EXPANSION OF THE HOLTSMANN GMBH - GERMANY

D

Mehr Erfolg am Point-of-Sale

Viele Kaufentscheidungen fallen nachweislich am Point-of-Sale, das heißt, vor dem Regal. Zu diesem Zweck entwickeln und produzieren wir professionell gestaltete, aufmerksamkeitsstarke Verpackungen. Sie unterstreichen die Qualität unserer Produkte und unterstützen Sie darin, Ihren Kunden unsere JOKOSIT Produkte verkaufsfördernd und Gewinn bringend zu präsentieren. Zudem erleichtern Tragegriffe an den Verpackungen das Handling.

GB

More success at the point of sale

It has been proven that many purchase decisions are made at the point of sale, i.e. in front of the shelf. With this in mind, we develop and produce eye-catching packaging designed by professionals. It highlights the quality of our products and will help you to present our JOKOSIT products to your customers in a manner that promotes sales and gives you a profit. The handles on the packaging also make the products easier to hold and carry.





Zu unseren bewährten Fliesenschneidemaschinen "Made in Germany" aus Eigenproduktion, besteht auch die Möglichkeit, sämtliches Zubehör in ansprechendem Jokosit Verpackungsdesign zu erhalten. Dies können wir durch das breit gefächerte Fliesenleger - Zubehörsortiment der Holtmann GmbH realisieren. Bitte sprechen Sie uns an, gerne erstellen wir Ihnen ein verkaufsförderndes Werkzeugwandkonzept. *In addition to the proven "Made in Germany" tile cutting machines which are produced on our own premises, we can also supply you with all the corresponding accessories in JOKOSIT packaging. Holtmann GmbH's diverse range of accessories allows us to do this. Please contact us if you are interested. We are happy to provide you with a wall concept that promotes sales.*

BASIC-CUT Series



BASIC-CUT 115 | Art.-Nr. / Item No. 115

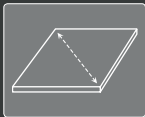

Schnittlänge
Cutting length
| 300 mm |

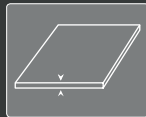

Fliesenstärke
Tile thickness up to
| 10 mm |

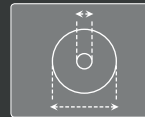

Ø HM Rädchen
Carbide cutting wheel
| 15 x 6 mm |

BASIC-CUT 111 | Art.-Nr. / Item No. 111

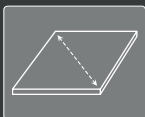
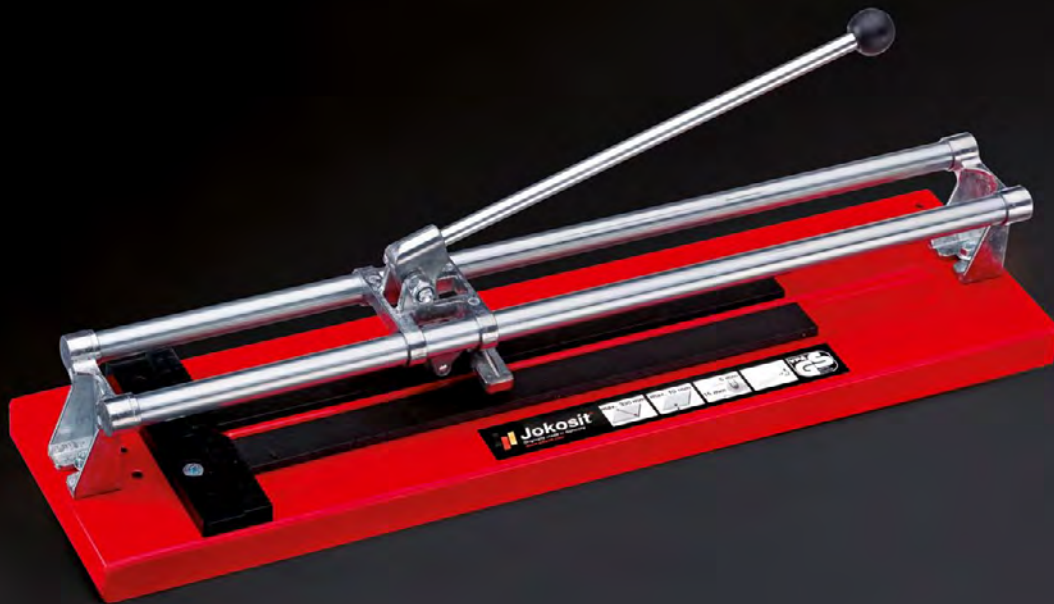

Schnittlänge
Cutting length
| 330 mm |

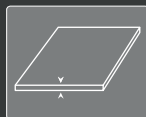

Fliesenstärke
Tile thickness up to
| 15 mm |

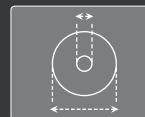

Ø HM Rädchen
Carbide cutting wheel
| 15 x 6 mm |

BASIC-CUT 112 | Art.-Nr. / Item No. 112



mit Anschlagwinkel 90°
with angle adjustment 90°

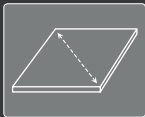

Schnittlänge
Cutting length
| 330 mm |

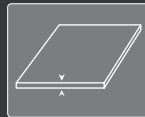

Fliesenstärke
Tile thickness up to
| 15 mm |

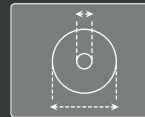

Ø HM Rädchen
Carbide cutting wheel
| 15 x 6 mm |

BASIC-CUT 166 | Art.-Nr. / Item No. 166

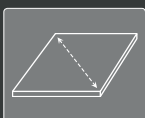

Schnittlänge
Cutting length
| 400 mm |

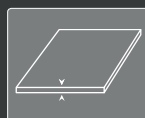

Fliesenstärke
Tile thickness up to
| 15 mm |

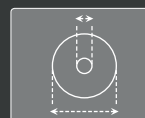

Ø HM Rädchen
Carbide cutting wheel
| 15 x 6 mm |

BASIC-CUT 167 | Art.-Nr. / Item No. 167



mit Anschlagwinkel 90°
with angle adjustment 90°

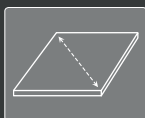

Schnittlänge
Cutting length
| 400 mm |

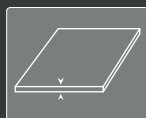

Fliesenstärke
Tile thickness up to
| 15 mm |

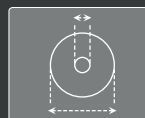

Ø HM Rädchen
Carbide cutting wheel
| 15 x 6 mm |

BASIC-CUT 153 | Art.-Nr. / Item No. 153 / 153 W



153 / mit Anschlagwinkel 90°
with angle adjustment 90°



153 W / mit verstellbarem
Anschlagwinkel 0-90°
with movable angle
adjustment 0-90°

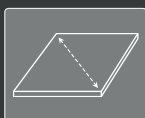

Schnittlänge
Cutting length
| 470 mm |

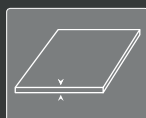

Fliesenstärke
Tile thickness up to
| 18 mm |

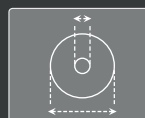

Ø HM Rädchen
Carbide cutting wheel
| 22 x 6 mm |

BASIC-CUT 154 | Art.-Nr. / Item No. 154 / 154 W



154 / mit Anschlagwinkel 90°
with angle adjustment 90°



154 W / mit verstellbarem
Anschlagwinkel 0-90°
with movable angle
adjustment 0-90°

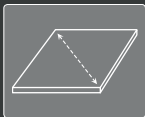

Schnittlänge
Cutting length
| 600 mm |

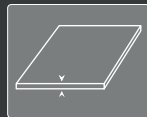

Fliesenstärke
Tile thickness up to
| 18 mm |

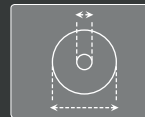

Ø HM Rädchen
Carbide cutting wheel
| 22 x 6 mm |

BASIC-CUT 158 | Art.-Nr. / Item No. 158 / 158 W



158 / mit Anschlagwinkel 90°
with angle adjustment 90°



158 W / mit verstellbarem
Anschlagwinkel 0-90°
with movable angle
adjustment 0-90°

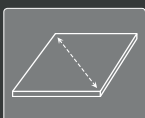

Schnittlänge
Cutting length
| 800 mm |

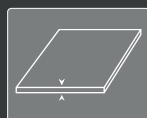

Fliesenstärke
Tile thickness up to
| 18 mm |

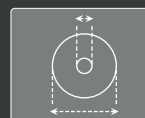

Ø HM Rädchen
Carbide cutting wheel
| 22 x 6 mm |



mit Anschlagwinkel 90°
with angle adjustment 90°



THE ORIGINAL
by Jokosit Design
since 1975

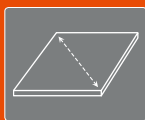

Schnittlänge
Cutting length
| 400 mm |

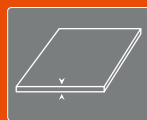

Fliesenstärke
Tile thickness up to
| 15 mm |



Ø HM Rädchen
Carbide cutting wheel
| 15 x 6 mm |



Prinzip des
verstellbaren
Anschlagwinkels
Principle of the
movable adjustment

Schnittlinie
Cutting line

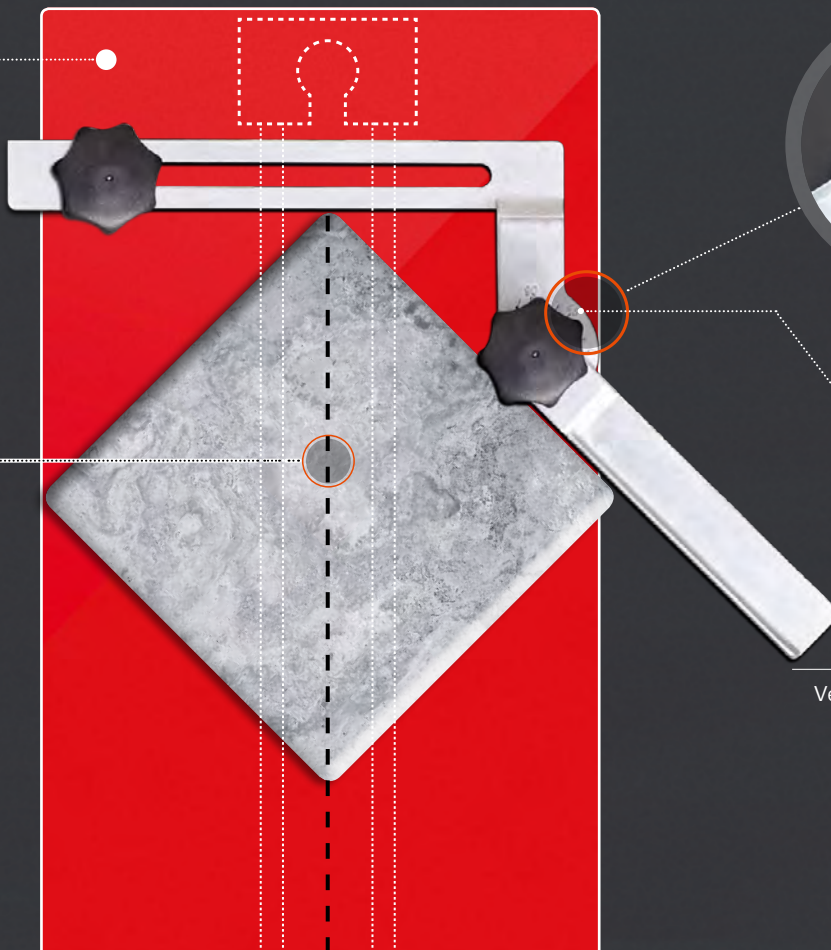

Verstellbarer Anschlagwinkel 0-90°
Movable angle adjustment 0-90°

PROFI-CUT Series

**Kugelgelagerte Fliesenschneidemaschinen
mit gehärteten und geschliffenen Voll-
materialführungswellen**
*Ball-bearing tile cutting machines with
hardened and ground shafts*



PROFI-CUT SERIES

Gehärtet sowie geschliffene Vollmaterialführungswellen für höchste Stabilität und größte Präzision
 Hardened and polished solid material guide shafts for outstanding stability and precision

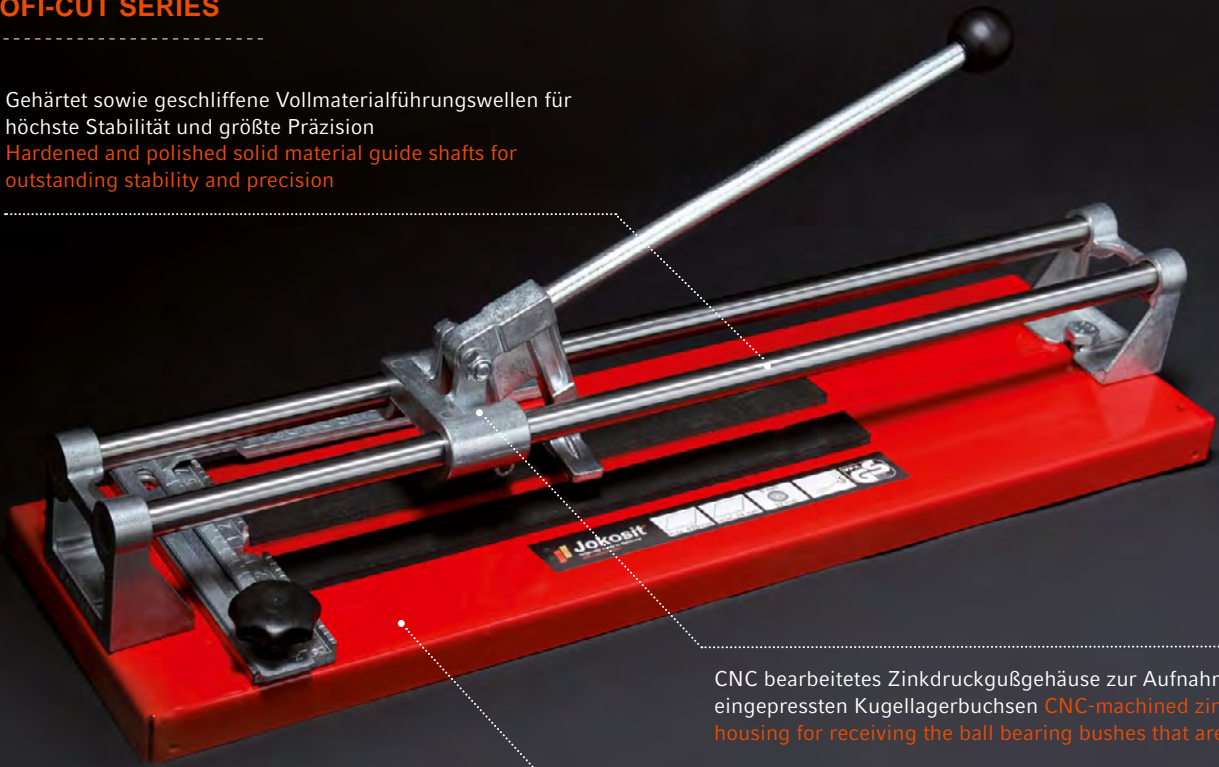

CNC bearbeitetes Zinkdruckgußgehäuse zur Aufnahme der eingepressten Kugellagerbuchsen
 CNC-machined zinc die-cast housing for receiving the ball bearing bushes that are pressed in

2,5 mm starkes Stahlblech, stoß und kratzfest, rot lackiert
 2.5 mm sheet steel, scratch- and impact-resistant and painted red

PROFI-CUT 163 | Art.-Nr. / Item No. 163 / 163 W



163 / mit Anschlagwinkel 90°
 with angle adjustment 90°



163 W / mit verstellbarem Anschlagwinkel 0-90°
 with movable angle adjustment 0-90°

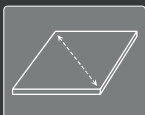
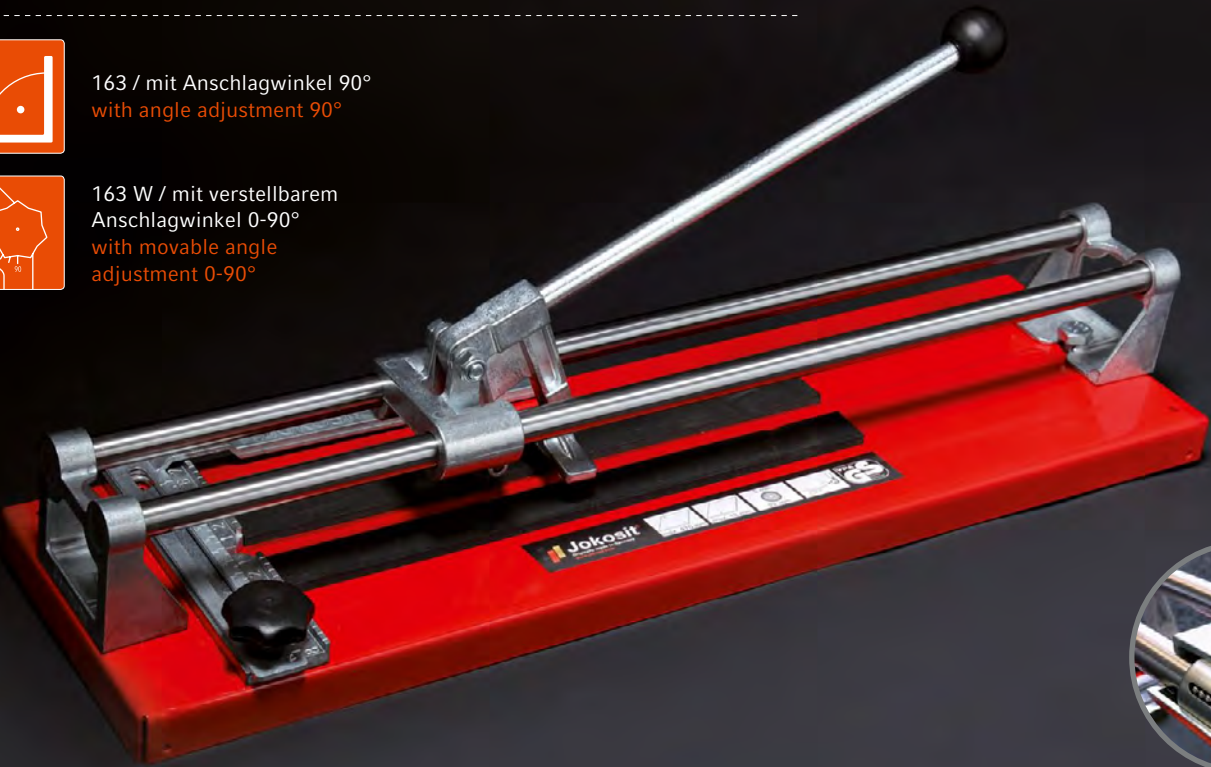

Schnittlänge
 Cutting length
 | 470 mm |

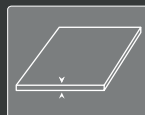

Fliesenstärke
 Tile thickness up to
 | 18 mm |

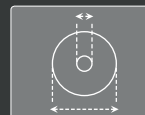

Ø HM Rädchen
 Carbide cutting wheel
 | 22 x 6 mm |



Kugellager
 Ball bearing

PROFI-CUT 164 | Art.-Nr. / Item No. 164 / 164 W



164 / mit Anschlagwinkel 90°
with angle adjustment 90°



164 W / mit verstellbarem
Anschlagwinkel 0-90°
with movable angle
adjustment 0-90°

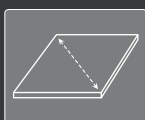

Schnittlänge
Cutting length
| 600 mm |

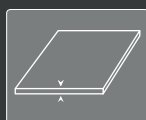

Fliesenstärke
Tile thickness up to
| 18 mm |

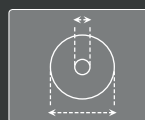

Ø HM Rädchen
Carbide cutting wheel
| 22 x 6 mm |



Kugellager
Ball bearing

PROFI-CUT 165 | Art.-Nr. / Item No. 165 / 165 W



165 / mit Anschlagwinkel 90°
with angle adjustment 90°



165 W / mit verstellbarem
Anschlagwinkel 0-90°
with movable angle
adjustment 0-90°

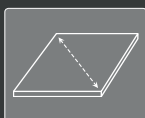
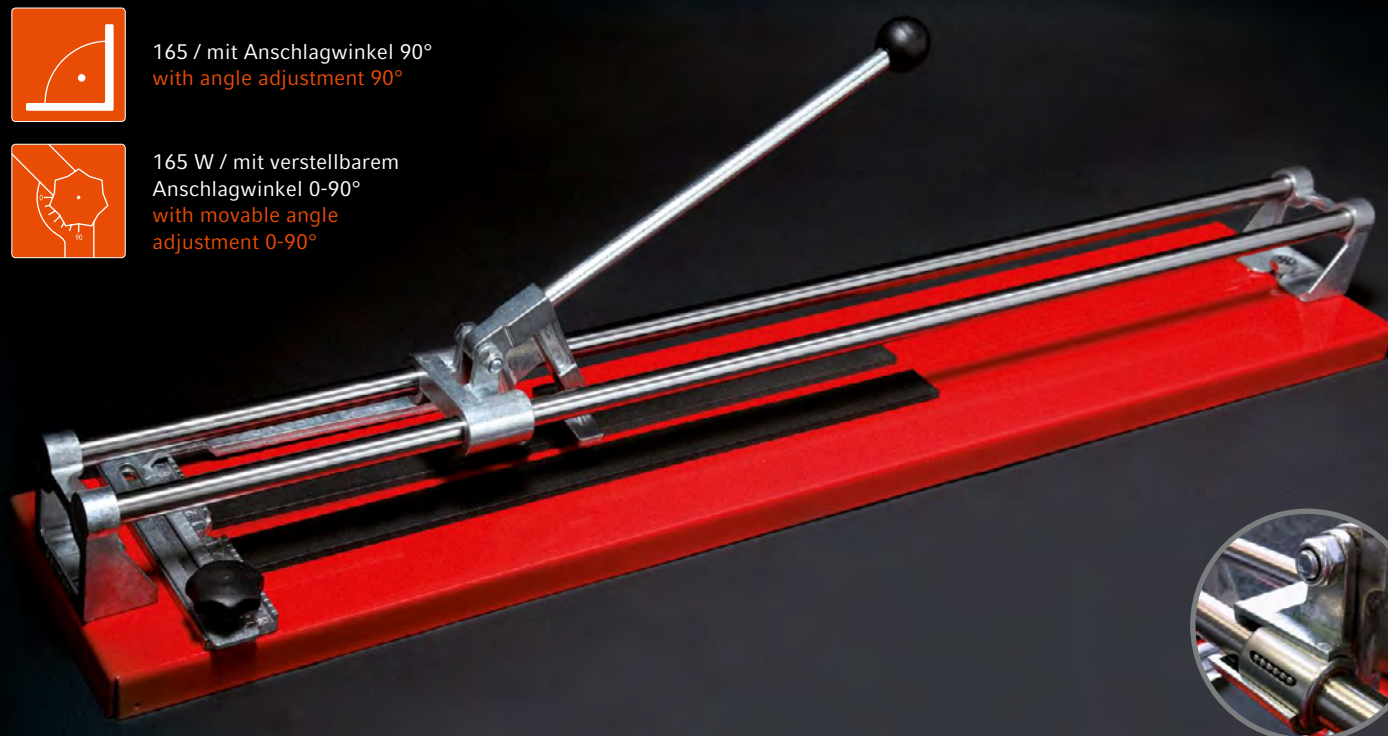

Schnittlänge
Cutting length
| 800 mm |

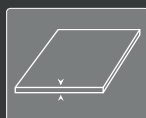

Fliesenstärke
Tile thickness up to
| 18 mm |

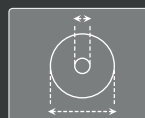

Ø HM Rädchen
Carbide cutting wheel
| 22 x 6 mm |



Kugellager
Ball bearing

PROFI-CUT 131 WOOD | Art.-Nr. / Item No. 131



131 / mit verstellbarem
Anschlagwinkel 0-90°
with movable angle
adjustment 0-90°

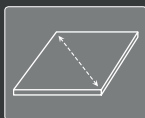
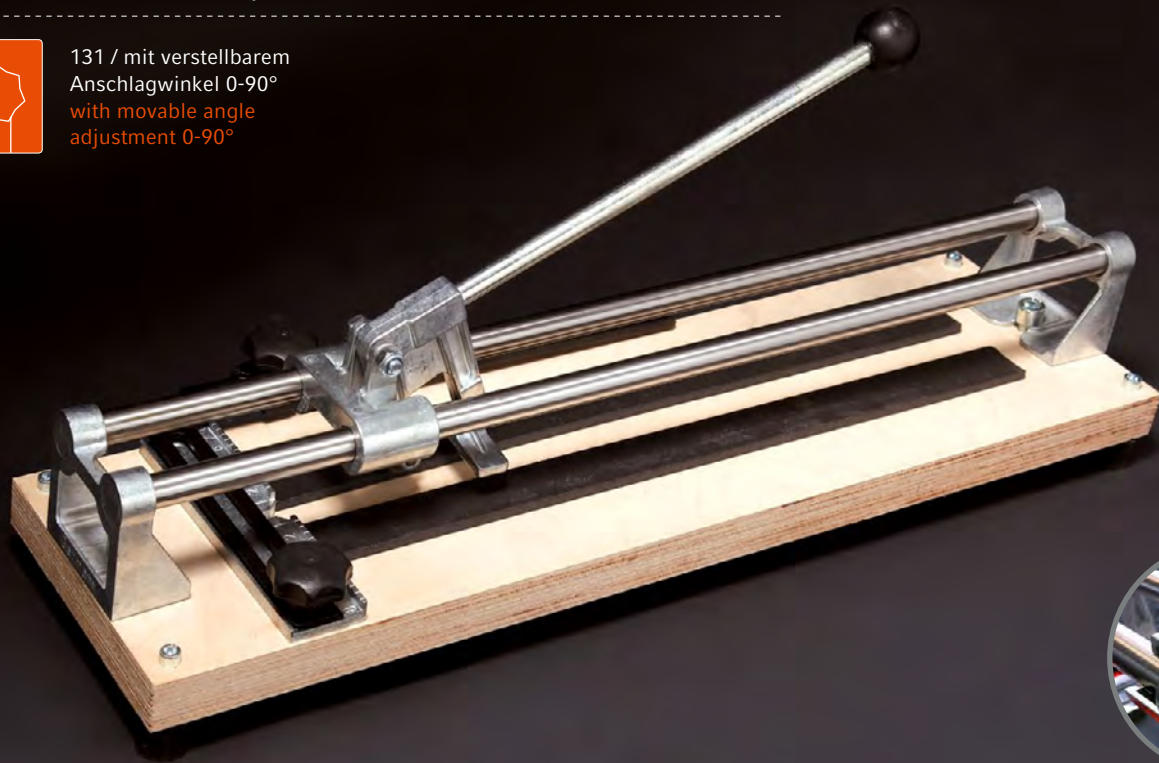

Schnittlänge
Cutting length
| 470 mm |

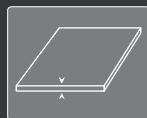

Fliesenstärke
Tile thickness up to
| 18 mm |

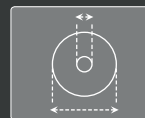

Ø HM Rädchen
Carbide cutting wheel
| 22 x 6 mm |



Kugellager
Ball bearing

PROFI-CUT 132 WOOD | Art.-Nr. / Item No. 132



132 / mit verstellbarem
Anschlagwinkel 0-90°
with movable angle
adjustment 0-90°

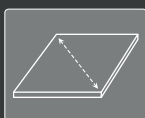
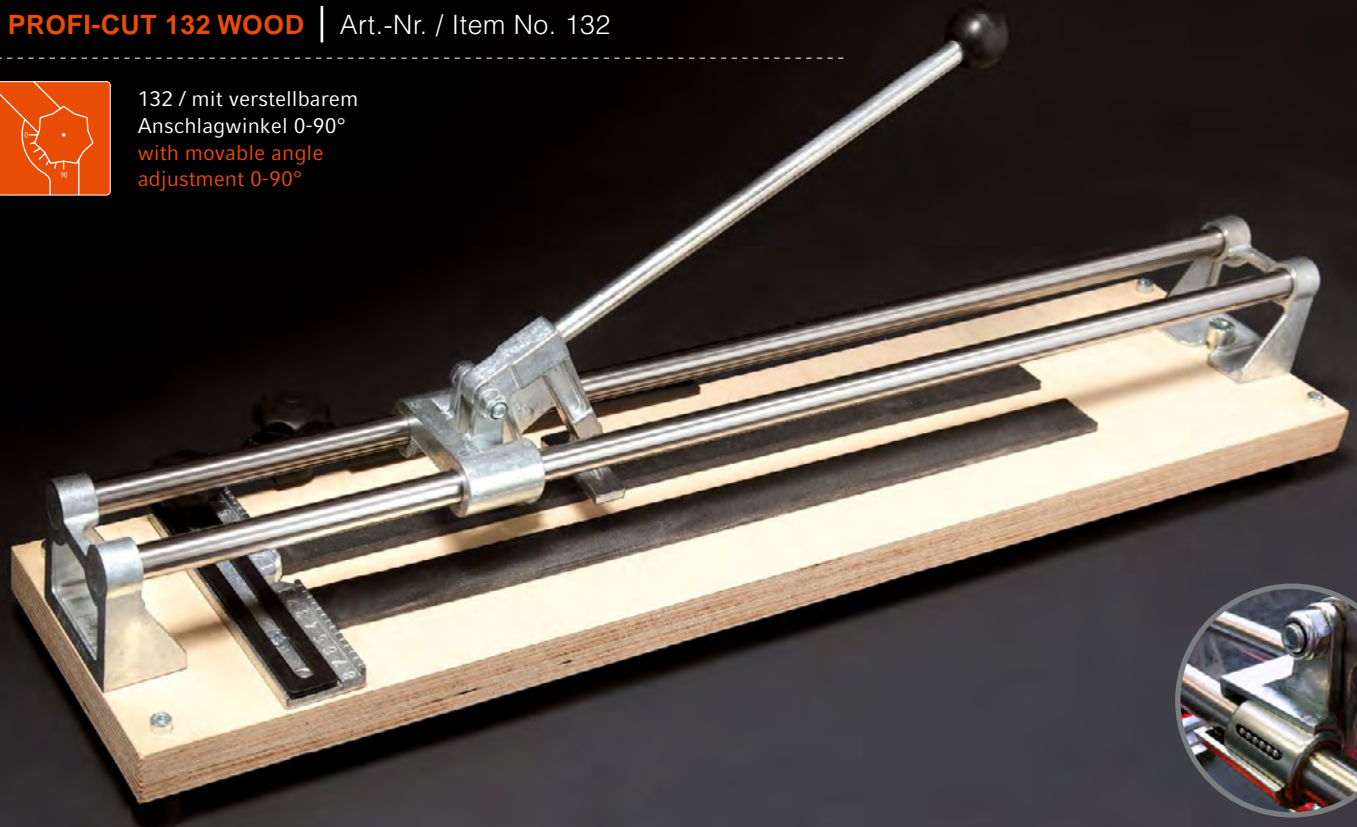

Schnittlänge
Cutting length
| 600 mm |

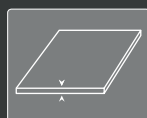

Fliesenstärke
Tile thickness up to
| 18 mm |

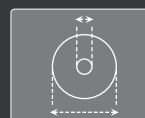

Ø HM Rädchen
Carbide cutting wheel
| 22 x 6 mm |



Kugellager
Ball bearing

PROFI-CUT 133 WOOD | Art.-Nr. / Item No. 133



133 / mit verstellbarem
Anschlagwinkel 0-90°
with movable angle
adjustment 0-90°

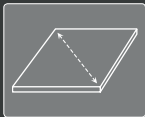
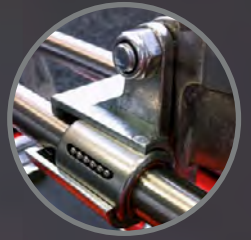
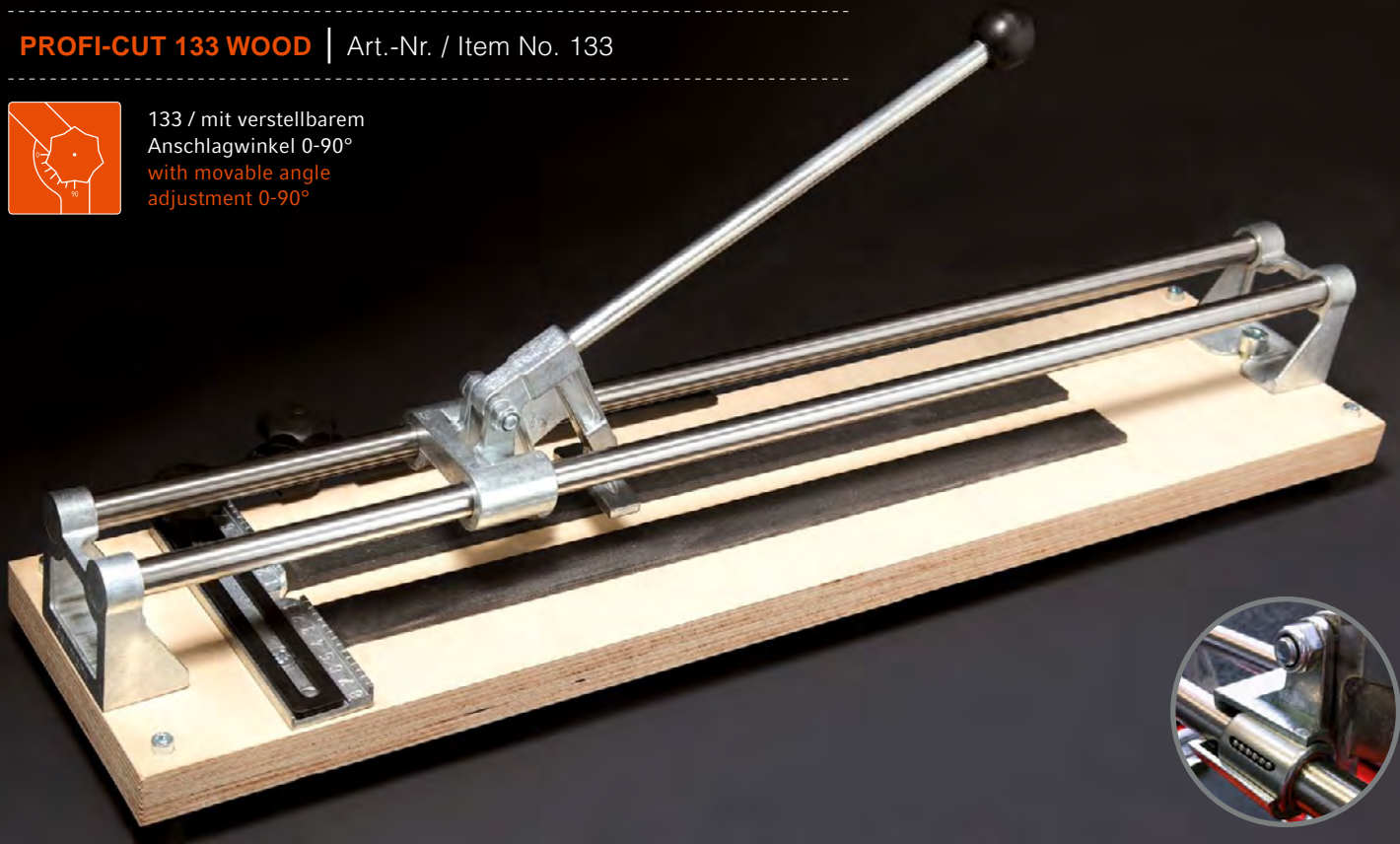

Schnittlänge
Cutting length
| 800 mm |

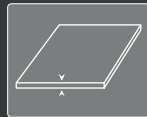

Fliesenstärke
Tile thickness up to
| 18 mm |

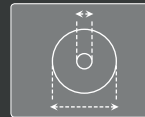

Ø HM Rädchen
Carbide cutting wheel
| 22 x 6 mm |



Kugellager
Ball bearing

PROFI-CUT 110 WOOD | Art.-Nr. / Item No. 110



110 / mit verstellbarem
Anschlagwinkel 0-90°
with movable angle
adjustment 0-90°

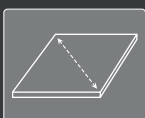
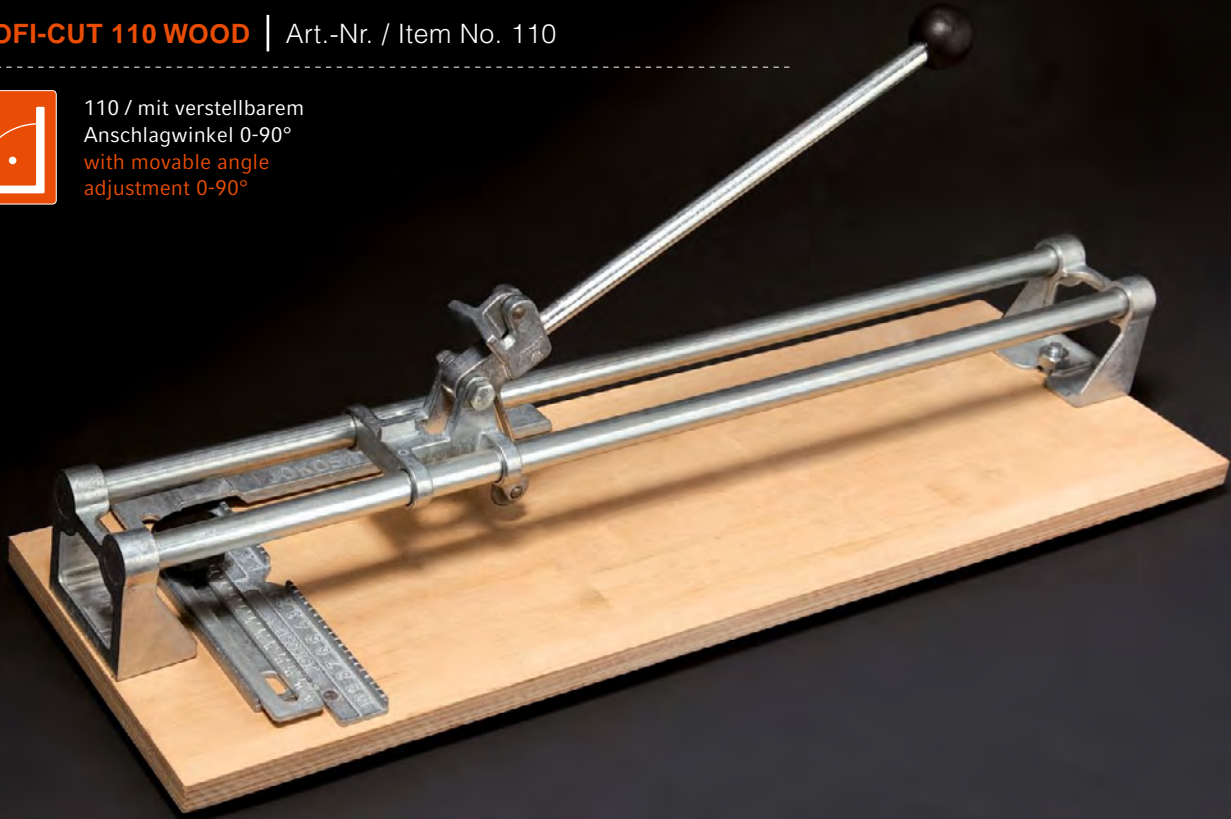

Schnittlänge
Cutting length
| 470 mm |

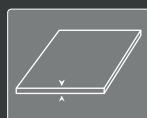

Fliesenstärke
Tile thickness up to
| 18 mm |

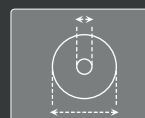

Ø HM Rädchen
Carbide cutting wheel
| 22 x 6 mm |

PRODUKTSET / PRODUCT SET

Art.-Nr. / Item No. 112 + 174 SET



mit Anschlagwinkel 90°
with angle adjustment 90°



Fliesenleger-Set 6-tlg. / Fliesenschneidemaschine,
Fliesen-Lochzange, Zahnspachtel, Fugengummi, Schwamm,
Spannecken **6-piece tile laying set** / Tile cutting machine,
tile punch pincers, toothed spatula, grouting spreader,
clamping corners, sponge

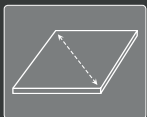

Schnittlänge
Cutting length
| 330 mm |

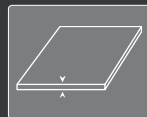

Fliesenstärke
Tile thickness up to
| 15 mm |

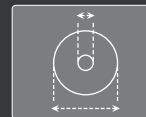

Ø HM Rädchen
Carbide cutting wheel
| 15 x 6 mm |

PRODUKTSET / PRODUCT SET

Art.-Nr. / Item No. 193 + 174 SET



mit Anschlagwinkel 90°
with angle adjustment 90°



Fliesenleger-Set 6-tlg. / Fliesenschneidemaschine,
Fliesen-Lochzange, Zahnspachtel, Fugengummi, Schwamm,
Spannecken **6-piece tile laying set** / Tile cutting machine,
tile punch pincers, toothed spatula, grouting spreader,
clamping corners, sponge

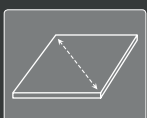

Schnittlänge
Cutting length
| 400 mm |

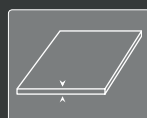

Fliesenstärke
Tile thickness up to
| 15 mm |

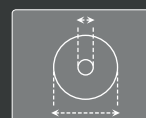

Ø HM Rädchen
Carbide cutting wheel
| 15 x 6 mm |

PRODUKTSET / PRODUCT SET

Art.-Nr. / Item No. 154 + 174 SET



mit Anschlagwinkel 90°
with angle adjustment 90°



Fliesenleger-Set 6tlg. / Fliesenschneidemaschine,
Fliesen-Lochzange, Zahnspachtel, Fugengummi, Schwamm,
Spannecken **6-piece tile laying set / Tile cutting machine,**
tile punch pincers, toothed spatula, grouting spreader,
clamping corners, sponge

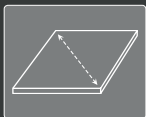

Schnittlänge
Cutting length
| 600 mm |

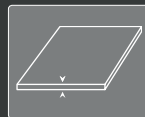

Fliesenstärke
Tile thickness up to
| 18 mm |

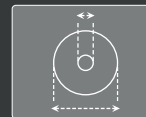

Ø HM Rädchen
Carbide cutting wheel
| 22 x 6 mm |

PRODUKTSET / PRODUCT SET

Art.-Nr. / Item No. 174 SET



Fliesen-Lochzange, Zahnspachtel, Fugengummi, Schwamm, Spannecken
Tile punch pincers, toothed spatula, grouting spreader, clamping corners, sponge

HARTMETALL-RÄDCHEN / Carbide cutting wheels



Hartmetall-Rädchen (geschliffen) - - 22 x 6 mm,
lose oder auf SB-Karte

Carbide cutting wheel with or without blister card
Artikelnummer / Item No. **053 / 053SB**

Hartmetall-Rädchen (geschliffen) - - 22 x 6 mm,
lose oder auf SB-Karte

Carbide cutting wheel with or without blister card
Artikelnummer / Item No. **053-TIN / 053-TIN SB**



Hartmetall-Rädchen (geschliffen) - - 15 x 6 mm,
lose oder auf SB-Karte

Carbide cutting wheel with or without blister card
Artikelnummer / Item No. **054 / 054SB**

Hartmetall-Rädchen (geschliffen) - - 14 x 6 mm,
lose oder auf SB-Karte

Carbide cutting wheel with or without blister card
Artikelnummer / Item No. **059-3 / 059-3SB**

ZUBEHÖR / Accessoires



040SB



040



041SB



041

Plattenschneider mit Hartmetallrädchen, lose oder auf SB-Karte / Plate cutter with carbide cutting wheel, with or without blister card

Artikelnummer / Item No. **040 / 040SB**

Plattenschneider mit Hartmetallschneide, lose oder auf SB-Karte / Plate cutter with carbide cutting edge, with or without blister card

Artikelnummer / Item No. **041 / 041SB**

ZUBEHÖR / Accessoires



059SB

059



059-1

Fliesen-Schneid- und Brechzange, Hartmetallrädchen 14 x 6 mm, lose oder auf SB-Karte / Tile cutting and breaking tongs, carbide cutting wheel, with or without blister card

Artikelnummer / Item No. **059 / 059SB**

Anschlag

Stop attachment

Artikelnummer / Item No. **059-1**



601SB

600



601

600SB



www.jokosit.com

www.jokosit.com











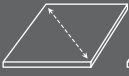
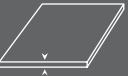













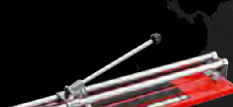

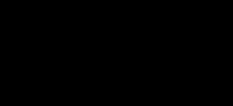

* Passend für alle gängigen Bohrmaschinen, Bohrbereich 30 – 80 mm
Fits all usual drills, drilling range 30 – 80

Fliesen-Lochschneider (Hartmetall) mit Handschutz *
Tile hole-cutter drill attachment with hand protection (carbide) *
Artikelnummer / Item No. **601** / verpackt packaged **601SB**

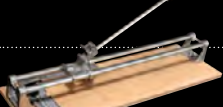
Fliesen-Lochschneider (Hartmetall) lose oder auf SB-Karte *
Tile hole-cutter drill attachment (carbide) with or without blister card
Artikelnummer / Item No. **600** / **600SB**

MASCHINENÜBERSICHT / Machine overview

								
Art.-Nr.	Schnittlänge	Fliesenstärke	HM-Rad	Anschlag-Winkel	verstellbarer Anschlagwinkel	Kugellager	Kartonmaß L x B x H mm	Gewicht
Item No.	Cutting length	Tile thickness up to	Carbide cutting wheel	Angle adjustment	Movable angle adjustment	Ball bearing	Box size L x B x H mm	Weight
 115	300 mm	10 mm	15 x 6 mm	X	X	X	480 x 145 x 130	2,4 Kg
 111	330 mm	15 mm	15 x 6 mm	X	X	X	480 x 145 x 130	2,5 Kg
 112	330 mm	15 mm	15 x 6 mm	✓	X	X	480 x 145 x 130	2,6 Kg
 193	400 mm	15 mm	15 x 6 mm	✓	X	X	635 x 200 x 135	3,4 Kg
 166	400 mm	15 mm	15 x 6 mm	X	X	X	550 x 145 x 130	2,7 Kg
 167	400 mm	15 mm	15 x 6 mm	✓	X	X	550 x 145 x 130	2,8 Kg
 153	470 mm	18 mm	22 x 6 mm	✓	X	X	625 x 210 x 130	5,5 Kg
 153W	470 mm	18 mm	22 x 6 mm	X	✓	X	625 x 210 x 130	5,5 Kg
 154	600 mm	18 mm	22 x 6 mm	✓	X	X	760 x 210 x 130	6,3 Kg
 154W	600 mm	18 mm	22 x 6 mm	X	✓	X	760 x 210 x 130	6,3 Kg
 158	800 mm	18 mm	22 x 6 mm	✓	X	X	960 x 210 x 130	7,6 Kg
 158W	800 mm	18 mm	22 x 6 mm	X	✓	X	960 x 210 x 130	7,6 Kg
 163	470 mm	18 mm	22 x 6 mm	✓	X	✓	625 x 210 x 130	6,6 Kg
 163W	470 mm	18 mm	22 x 6 mm	X	✓	✓	625 x 210 x 130	6,6 Kg
 164	600 mm	18 mm	22 x 6 mm	✓	X	✓	760 x 210 x 130	7,7 Kg
 164W	600 mm	18 mm	22 x 6 mm	X	✓	✓	760 x 210 x 130	7,7 Kg
 165	800 mm	18 mm	22 x 6 mm	✓	X	✓	960 x 210 x 130	9,3 Kg
 165W	800 mm	18 mm	22 x 6 mm	X	✓	✓	960 x 210 x 130	9,3 Kg
 110	470 mm	15 mm	22 x 6 mm	✓	X	X	760 x 195 x 160	4,2 Kg
 131	470 mm	18 mm	22 x 6 mm	X	✓	✓	760 x 195 x 160	5,6 Kg
 132	600 mm	18 mm	22 x 6 mm	X	✓	✓	760 x 195 x 160	6,2 Kg
 133	800 mm	18 mm	22 x 6 mm	X	✓	✓	960 x 195 x 170	7,2 Kg

ALLGEMEINE GESCHÄFTSBEDINGUNGEN

Unsere Preise sind freibleibend. Die in den Auftragsbestätigungen angegebenen Lieferzeiten sind Richtwerte, die wir uns bemühen einzuhalten.

Der Versand erfolgt auf alleinige Rechnung und Gefahr des Bestellers. Für den Fall, dass Ihre Bestellung nicht mit unseren Verpackungseinheiten korrespondiert, behalten wir uns vor, diese in der nächst höheren oder niedrigeren Paketnorm zu liefern.

Bei Lieferung von Werkzeugen in besonderer Ausführung sind Mehr- oder Minderlieferungen gestattet. Wir übernehmen für die von uns gelieferten Werkzeuge die volle Garantie. Werkzeuge, die durch fehlerhafte Herstellung nicht einsetzbar sind, werden kostenlos ersetzt. Andere Ansprüche sind ausgeschlossen.

Die gelieferte Ware bleibt bis zur vollständigen Zahlung des Kaufpreises unser Eigentum. Im Falle der Weiterveräußerung der gelieferten Ware geht die dadurch entstandene Kaufpreisforderung ohne Weiteres auf uns über. Von Pfändungen sind wir sofort in Kenntnis zu setzen.

Alle Preise verstehen sich in Euro per Stück plus der gesetzlichen MwSt. Gerichtsstand und Erfüllungsort ist Wuppertal.

Die im Katalog angegebenen Beschreibungen, Maße und Abbildungen sind unverbindlich. Technische Änderungen sind vorbehalten. Das Nachdrucken oder Kopieren, auch auszugsweise, ist grundsätzlich nicht gestattet.

ZAHLUNGSBEDINGUNGEN:

Unsere Zahlungsbedingungen lauten:
innerhalb von 14 Tagen 3 % Skonto oder 30 Tagen netto

LIEFERBEDINGUNGEN DEUTSCHLAND:

Wir liefern ab Euro 500,00 frei Haus /
Ab Euro 250,00 bis Euro 500,00 mit Euro 7,50 Kostenanteil /
Ab Euro 150,00 bis Euro 250,00 mit Euro 15,00 Kostenanteil /
Lieferungen unter Euro 150,00 sind aus Kostengründen nicht möglich.

LIEFERBEDINGUNGEN EUROPA:

Wir liefern ab Euro 1250,00 Nettowarenwert frei deutsche Grenze.

Alle in diesem Katalog angegebenen Preise verstehen sich zuzüglich der gesetzlichen Mehrwertsteuer.

GENERAL TERMS AND CONDITIONS

Our prices are subject to change. The delivery times stated in our order confirmations are approximate guidelines which we try to adhere to.

Ordered items are shipped at the expense and risk of the ordering party. In cases where your order does not correspond to our packaging units, we reserve the right to deliver it in the next largest or next smallest size.

In the case of special models of tools, short and over-deliveries are permitted. We offer a full guarantee for the tools supplied by us. Tools that cannot be used due to substandard manufacturing are replaced free of charge. Other claims cannot be made.

The items supplied remain our property until the purchase price has been paid in full. If the items supplied are resold, the purchase price claim arising from the resale is transferred to us immediately. You are obliged to inform us of any distraint immediately.

All our prices are in euros per piece plus VAT at the statutory rate. Wuppertal is the legal venue and place of performance.

The descriptions, dimensions and images in this catalogue are not binding. We reserve the right to make technical changes. Reproductions and copies, including reproductions and copies of extracts, are not permitted.

TERMS OF PAYMENT:

Payments may be made within 14 days with a 3 % discount or within 30 days with no discount.

TERMS OF DELIVERY FOR GERMANY:

We deliver orders worth EUR 500.00 or more free of charge /
For orders worth between EUR 250.00 and EUR 500.00, the ordering party is required to pay an additional delivery cost of EUR 7.50 /
For orders worth between EUR 150.00 and EUR 250.00 the ordering party is required to pay an additional delivery cost of EUR 15.00 /
Orders worth under EUR 150.00 cannot be delivered due to cost reasons.

TERMS OF DELIVERY FOR EUROPE:

We pay the delivery costs up to the German border for orders with a net value of at least EUR 1250.00.

All the prices in this catalogue exclude VAT at the statutory rate.